

Lesson 1: Diagram Program Work Environment

The Program Screen:

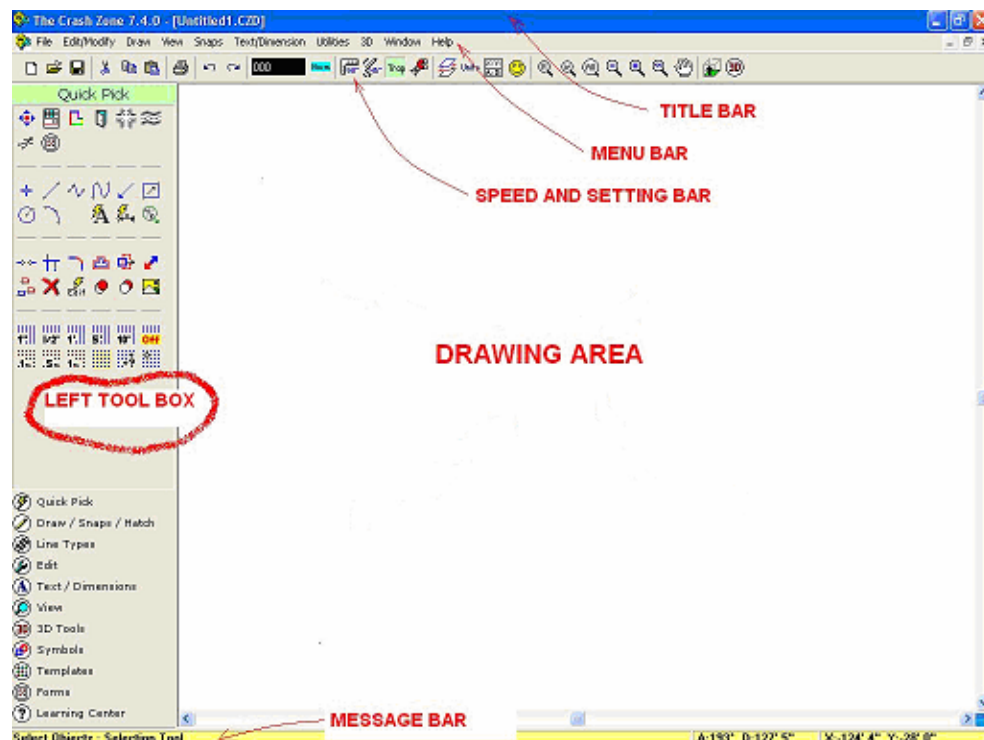

Title Bar – Software, version number and drawing name are displayed in blue bar.

Menu Bar – pull-down menus of all the program commands. These commands are also available in a button Icon format in Left Side Tool Box.

Speed / Settings Dialog Bar – command shortcuts for basic Windows functions to open, create new drawing, copy/paste, save, undo, redo, properties display, drawing aids and viewing tools.

MESSAGE BAR - The yellow colored Status/Message Bar is the last line at the bottom of the CAD Zone Window and provides some VERY useful functions:

The Message Bar on lower LEFT side has 3 functions:

- 1.) as you perform the various commands, the **Message Bar will give you step by step instruction to complete the task.** The CAD Zone System will be much easier to learn and use if you will get in the habit of following the instructions as they appear on the Status/Message Bar.
- 2.) You can Click on an object and it displays Object Properties (length, angle, etc.)
- 3.) It is also the Command line where you can see any typed commands such as the two-letter shortcuts or type in a value to define a Distance.

On the lower RIGHT side there is a dynamic Angle-Distance and a XY Coordinate display that allows you to view these properties as you are drawing.

DRAWING AREA – or computer paper

The Drawing Window is the area that covers the center portion of the screen. This is the area where you make your scaled diagrams.

There are Scroll Bars at the right and bottom of the Drawing Window that enable you to scroll (move up/down or side-to-side) when the drawing is too large to fit in the viewing area. There are also Viewing Tools at top Speed bar to help you maneuver about.

MOUSE POINTER

Almost all operations you do will be with the **LEFT mouse button**. The Mouse Pointer starts as an Arrow Pointer but will change depending on which feature you are using.



The **Arrow Pointer** is the default and when your mouse pointer looks like an arrow, you are in “**selection mode**” which means you can **select an object** in the drawing or **select a command** Icon from the Toolbars.



If the Mouse Pointer looks like a cross hair you **ARE** performing a command.



If the Mouse Pointer looks like a cross hair enclosed in a circle, Auto **Snap is turned on**. When you have Auto Snap turned on, the cursor will snap to a point, line or object within the Target circle so you can draw with. To turn Auto Snap on/off, select the **red magnet icon** on top speed bar.

precision



The 4-sided arrow allows you to **MOVE** selected object (s).



Small blue boxes are **Grips** (handles) that allow you to **Stretch or Rotate** objects. (Must be zoomed in close enough to object for them to appear).



Red Rotation Handle is the square and the target is the pivot point.

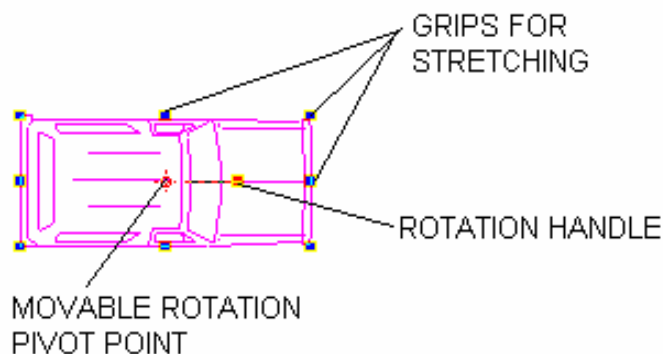

OPENING SCREEN OPTIONS:

OPEN: Open existing drawing

NEW: Start a new drawing

LEARN: Learning center with tutorials, movies, manual, etc.

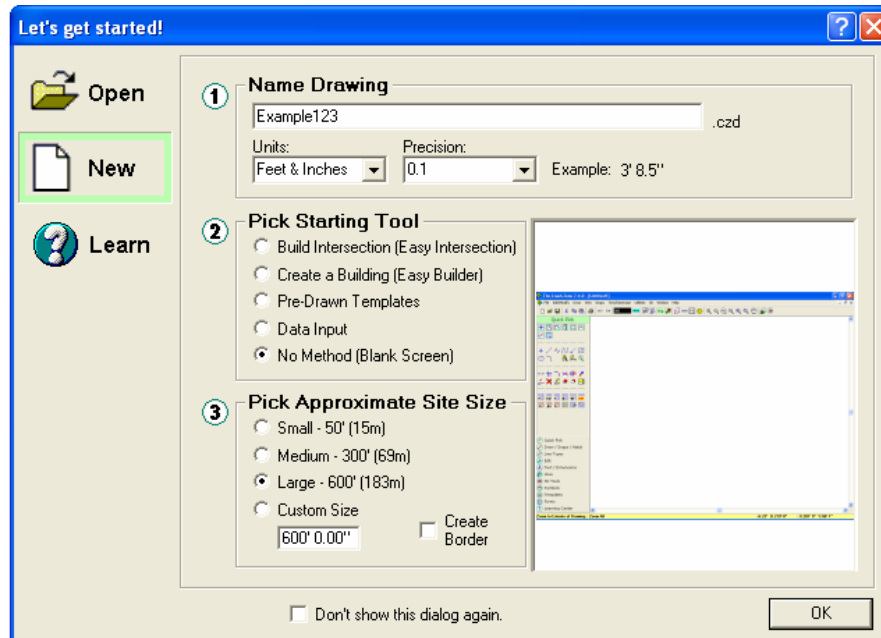

EXERCISE: Explore each option on this opening screen to become familiar with them.

- with a NEW drawing: Name Diagram, set Units & Precision. (Note: you must provide a diagram to save your work.)
- the Starting Tools will be described in more detail in later sections

FILE SAVE LOCATION:

Factory Default for version 7.5 saves drawings to:

C:\Documents and Settings\Your Name\My Documents\My Cad Zone\Diagrams

To change file save location: Go to UTILITIES pull-down > SETTINGS > PATHS

At the bottom, UNCHECK "Use Special Folders" box to save under Program folders or else use the "Save to Original Folder" check box for your own save locations.

With 'Use special folders' everything is saved in your user profiles. We recommend this if the user is NOT Administrator to their local machine. Other than that, our pathing, without any of the options checked, works just like any other program. We open and save in the last location you opened a document.

Fundamentals and Concepts to completing a diagram:

- 1) Draw the building, road, or site using measurements
- 2) Place Symbols
- 3) Place Text and Dimensions

- 4) Add a Form & Save
- 5) Print the drawing

A **SCALED factual diagram** is necessary to provide an accurate scene diagram that will stand up in court and also for the program functions and features to work optimally.

SETTINGS TO WATCH:

Ortho (Angle Draw), Ortho Trap and Auto Snaps options in speed bar:



Ortho Icon looks like a small carpenter's square so you can think of it for drawing straight lines and perfect 90 degree corners and 45 angles.



Ortho Trap will “trap” your mouse movement when drawing a line at: 0, 45 or 90 degrees when your mouse gets close (not as restricting as the ortho mode).



Auto Snaps Icon looks like a Horseshoe Magnet. It allows precise drawing and measuring to “Snap” onto a point or exact end of a line.

If these Icons are turned on, they will look “pressed in” and have a green background. If they are turned off they will have a gray background and look like the other Icons.

Useful Tips - The following is a list of useful keys on the Keyboard

1. The ESC key can be used to “back-up” or “back-out” when doing a command. Also Double Clicking will end some commands like continuous line or copy.
2. Pressing the Space Bar will REPEAT the previous CAD Zone command.
3. You can point to any Icon on a Toolbar with the mouse pointer, wait a few seconds and bubble help displays that describes the command for that Icon.
4. If your cursor seems to disappear when you try to move it, you are in the middle of a command. Clicking the Left Mouse Button or hitting the ESC key a few times will usually get your cursor back and close out the command.
5. Remember to use the Undo and Redo  commands located on the Speed bar if you make a mistake.
6. Command Line is a yellow line at the bottom left, and is very important since it prompts you for next steps required for the command. It also displays Object Properties if you click on an object then move the mouse near you then view: length, angle, and layer.
7. Angle-Distance and XY Coordinates display dynamically at the bottom right. You can use this to guide you when drawing lines, moving objects, etc.

LEFT-HAND TOOLBOX

While all of the commands can be found on the Pull-Down menus, the left-hand toolbox offers a quicker way to select many of the most commonly used commands. The commands found on the **toolbox are arranged in “Bins or Tool Drawers”** where there are groups of similar features just as the commands are arranged on the pull-down menus.

SELECTING COMMANDS - three methods:

1. **Pull Down menus**
2. **Left Toolbox and Speed Bar buttons**
3. **Typed Keyboard Shortcuts:** there are two-letter codes for every command in the program. (The appear beside the command. When typing you can see the letters appear in the command line down in the lower left corner of the screen.)

Lesson 2: Selecting Objects and Selection Tools

To modify objects on screen you need to select the object(s) first. You can click on them using your left mouse button or use a “window” to select multiple objects. The selected objects will highlight magenta in color so you can tell that have been selected.

For **multiple selections**, hold down either the **Ctrl or Shift** button while using your left mouse to select or de-select objects.

If you forget to pick your object first and select an Edit or Modify command, a Selection Bar similar to this one below may appear prompting you with options on various ways of selecting your object. It can be a bit confusing when you are starting off, so try to remember to pick the object first before most of the commands:

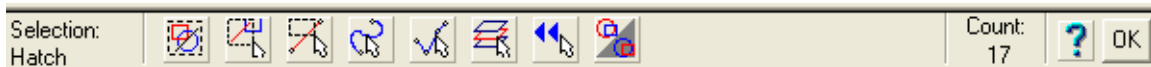

EXERCISE: Load an existing diagram from the sample drawings and perform the following concepts:

- 1.) To edit (or modify) objects in your drawing, they must first be **selected**. Click on object or use a drag windows selection method to select objects:
 - **Left to Right window**: selects only the objects fully enclosed inside.
 - **Right to Left window** selects everything touched inside the window.
- 2.) When objects are selected they change to a magenta color and they are enclosed in eight blue Handles or Grips. Use handles to change the **SIZE** using the corners to change XY axis proportionally. The side grips stretch in one direction. (Make sure you are zoomed in close enough or they will not appear.)
- 4.) To **ROTATE your object** you can use the Red Rotation handle that pivots around the red target point. You can drag the target (pivot) point to a corner if desired and the object can then be rotated around this point.
- 5.) When you point to a selected object with the cursor, you will see a four-headed arrow attached to the cursor. When this happens, you can hold down the left mouse button and **MOVE** the object. Let go left mouse to drop into place.

Lesson 3: View Commands



There are also several different View commands available in the top speed bar to allow you to maneuver around as you work on your diagram. It is best to be zoomed in closer when you are working in an area to be more precise in what you are doing.

EXERCISE: With sample drawing loaded practice the following concepts.

Zoom Window – use your mouse to define the area you want a close up of to make object inside appear larger and hide the outside part from view.

Zoom All – Causes all of the objects in your diagram to be displayed on the screen.

Zoom In/Out – increases or decreases your screen view

Refresh – Cleans up the screen by clearing up any stray marks or reference lines that were left by editing or erasing.

Zoom Previous takes you back to the previous view

Pan turns your mouse into a “Hand” to push your drawing easily around your screen (use Esc key or pick a drawing command to end this command).

Scroll Bars on side and bottom

If you have a MOUSE with a ROLLER WHEEL you can use the wheel to Zoom in and out very quickly. If your mouse does not have this active you can go to your mouse settings and activate it for the CAD Zone program.

When you are in Crash or CrimeZone, got to the Control Panel and go to the Mouse icon. The options will vary depending on your mouse type but you should be able to find the setting listing the CrimeZone or CrashZone to make the mouse functions active.

CAD ZONE’S “TOOL DRAWERS” or TOOL BINS:



QUICKPICK MENU

Provides most of your commonly used commands in one menu allowing you to draw more efficiently:



EASY LINES ROUTINES, DATA TABLE ENTRY, EASY BUILDER,
EASY Doors-Windows, EASY INTERSECTION, EASY STREET OFFSETS,
BODY BUILDER AND BORDERS

COMMON DRAWING COMMANDS
QUICK TEXT, QUICK DIMENSIONS and BUBBLE LABELS

COMMON EDITING-MODIFYING COMMANDS:
Break, Trim-Extend, Fillet curve, Offset, Stretch & Move
Copy, Delete, EDIT, Bring to front, Send to back, INSERT DIGITAL IMAGE

GRIDS: SET VARIOUS SPACING in Inches, Feet or Meters or Set own
grid spacing. Like working on Graph Paper - lines snap to points

Lesson 4: Drawing Basic Objects

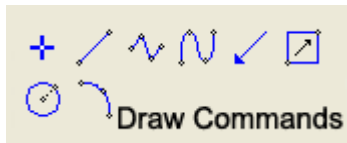

There are basic drawing commands included in the program for drawing lines, circles, boxes, curves, and arcs. Use these tools to construct streets, driveways, parking lots, rivers, and any other features of a site.

EXERCISE:

1. Select the Rectangle command from the left-hand toolbox.
2. Click two points to define the corners of the rectangle.
3. Refer to the Message Bar at the bottom of the screen for instructions on what to do next.
4. Refer to the distance read-out (X and Y measurement at bottom right) to see how far you have moved your cursor, so you know how large to make the rectangle. The X measurement is the horizontal distance and the Y measurement is the vertical distance you have moved since the last click.

You will quickly see that with this method it takes a very steady hand to create an object to an exact size. Next, let's look at some easier ways to draw accurately.

Direct Distance Method

An easy way to draw objects to exact measurements is to use the "Direct-Distance" method of entering distances. Let's draw that rectangle again and use Direct Distance to specify the size:

1. Select the two-point rectangle command.
2. Click once to place the lower left-hand corner of the rectangle.
3. On the keyboard, type the width of the rectangle, a comma, and then the height.
4. Press the Enter key and the rectangle will then be drawn with the exact measurements you entered.



10,30

< This is an example of typing 10,30 so you get a 10' x 30' rectangle

- You can also use this method to draw other basic objects, like single line segments, continuous lines, circles, etc.
- **For a line**, you simply select the Line command, click to place the first point, move the cursor in the direction you want the line to go and **type in the length** of the line on the keyboard. Press Enter to complete command.
- Try each of the draw commands to do a line, circle, spline (curving line) & arc.

Lesson 5: Ortho Angle Draw

Ortho is an abbreviation for orthogonal, meaning **at right angles** or **perpendicular**. Much of your work consists of drawing lines in exactly horizontal, vertical or diagonal directions. To make this easier, the system provides three Icons that restrict the cursor movement:

Using Ortho (Angle Draw):



The Ortho Icon is on the Angle Bar and looks like a carpenter's square for restricted 0 and 90 degree movement and to the right is the Angle 45 Icon.

You turn Angle Draw ON by selecting either the Angle 0 or the Angle 45 Icon; they will display a green background and will constrain the movement of the cursor.

EXERCISES:

1. Select the Angle 45 Icon and the cursor will only move in diagonal directions of 45 degrees. To switch to horizontal or vertical, select the Angle 0 Icon.
2. Select the Angle 0 Icon and the cursor will only move in horizontal or vertical directions. To switch to diagonal movement of the cursor, select the Angle 45 Icon.
3. You can turn any of these Icons on before or in the midst of a drawing or editing command.
4. Draw a Single Line using Angle Draw.
5. Select the Angle 0 Icon.
6. Use the Single Line command to draw a horizontal and then a vertical line.
7. The point where you first click with the mouse pointer is the point from which you can either move the cursor horizontally or vertically. If you move the cursor in a horizontal line you must go back to the starting point to move the cursor in a vertical line.
8. Remember the “Undo Last Operation” Icon and the “Redo” Icons if you made an error and need to go back.
9. Select the Angle 45 Icon and use the line command to draw two diagonal lines.
10. Turn-off all the Ortho off and draw a single line. When Angle Draw is turned off, you can see that the cursor can be moved in any direction freely.

You can use the Angle Draw features to help draw any objects (line, arcs, curves), move items in a straight line, and rotate items in 90 degree increments. Also very useful in placing text straight on diagram.

Lesson 6: Auto Snaps



Auto Snaps Icon looks like a Horseshoe Magnet. This feature allows you to make **precise and tidy** looking drawings. It is also used for dimensioning and allows you to “Snap” onto a point or exact end of a line. Snaps are also very important for doing 3D line work and surfaces.



You can always know when Auto Snaps is on, the cursor will be a cross-hair enclosed in a circle. When Auto Snaps is off, there will be no circle.

With Auto Snaps turned On, a snap is performed if there is any part of the object inside the target cursor (circle). If there is no endpoint or object within the Auto Snaps cursor, the point is placed at the cursor location without snapping.

EXERCISE:

Continue with same Road 1 drawing. Make sure that the Ortho draw Icon is turned off so you can move mouse freely again.

Use the Single Line command to create two separate lines aligned horizontally across from each other with space between them, example below:



1. Turn-on the Auto Snap function.
2. Use Single Line command again. Click on one end of the line making sure the end is inside the Auto Snaps Target, then click on other line to join them.
3. The line should now look like it is one solid line, however, it is three separate lines connected together to form one line. Left click in different parts of the line to see the selection handles surround the different sections of the line.

Note: there are more **advanced** “snap” options in the Draw/Snaps/Hatch tool bin that include snapping to: mid-point, center of a circle, perpendicular, etc.

Lesson 7: Easy Street



Automated Offsets for Curved Sections of Road

- 1.) First **draw a curved line** that will depict one side or else the center line of the road you plan to draw using the **Spline Curve** line draw command.
- 2.) **Select** the curved line so it highlights.
- 3.) Next click the “**Easy Street**” button to bring up dialog as show below.
- 4.) Set the number of lanes by checking box, set widths and line types.
- 5.) When satisfied with the preview at top, click “**Apply**” which will add parallel offsets to your curved line on the drawing screen as shown below:

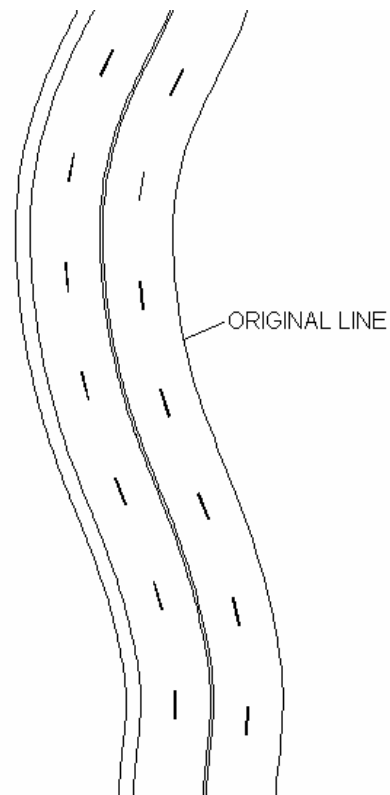
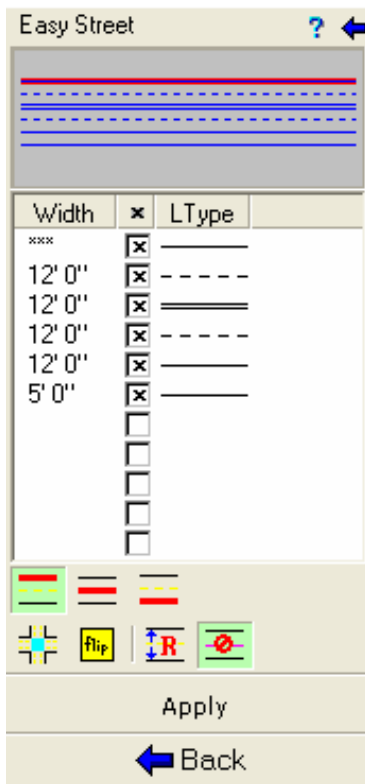

Lesson 8: Editing Options



QUICK PICK EDITING commands



BREAK: allows to “erase” a section of a line or object

This command can be useful when drawing intersections, driveway, merging lanes, etc.

EXERCISE: to create a Break in a line > START NEW “EDIT” DRAWING

Select the line, then go to the Left-hand Quick Pick Toolbar and select the Break Icon. (Follow the instruction in the message bar too.)

Click the mouse pointer on the line where you want the break to begin. The break will start at the point closest to the place you point. The mouse pointer cross-hair must touch the line.

Move your mouse pointer along the line and a dynamic preview of the break (line erasing) follows the cursor movement.

Click on the line where you want the break to end. You now have two lines.



TRIM & EXTEND: lengthen or shorten lines precisely to other lines

You can use this command to trim or extend lines, continuous lines, arcs, and curves. For example, when creating a building or intersection you can trim or extend a line that represents one side so it connects precisely to another.

EXERCISE: Using Trim & Extend command

Use the Single Line command and draw 4 single lines (about 50-60' each) to form a box shape. When drawing the box, make 2 of the corners overlap and 2 of them too short (not connected).

1. From Left-hand Quick Pick Toolbox, select the Trim & Extend Icon.
2. To trim two lines so they match precisely, first select the line that needs to be trimmed (too long) or extended (too short).
3. Next, select the line to which you want to trim/extend the first line to meet.
4. Perform this process for each corner of the box.



FILLET: make a curve between 2 points (defined radius)

EXERCISE: using Fillet command

Use the Fillet command to create rounded corners between lines, arcs, and rectangles.

(Continue to use the box drawn in the previous step to perform this exercise).

1. To fillet two objects:

2. From Left-hand Quick Pick Toolbox, select the Fillet Icon
3. The Fillet Settings Bar pops-up below your speed bar just above your drawing area so you can type in the precise radius for your fillet curve.
4. Enter 10 in the “Fillet Radius” text box to set to make a 10 foot radius fillet.
5. Click the first line to be filleted.
6. Click the second line to be filleted.
7. Move your cursor around the area and notice the preview of the fillet arc moves to give you different placement options.
8. Click when the preview fillet arc is in the correct location.
9. The filleted objects will be trimmed automatically to meet the fillet arc exactly at the tangent points.

TIP: you can set the radius to 0 (zero) to make a sharp corner if you wish.



OFFSET: to make a parallel copy or double up lines

Use the Offset command to make parallel copies of: single lines, continuous lines, polygons, curves, circles, arcs, or ellipses. Applications can be for making double walls or adding sidewalks, extra road lane, etc.

EXERCISE: Using Offset command

1. Draw a line on your drawing which will be the “base” for the drawing additional parallel lines.
2. From Left-hand Quick Pick Toolbox, select the Offset Icon. A Settings Bar will appear below the top Speed bar. It displays an “Offset distance” box that contains a value and a check-box labeled “Fixed distance.”
3. If the Fixed Distance check-box is checked, this will be the offset distance between the original object and the new, parallel object. Click either side.
4. If more than one object is selected to be offset, a fixed offset distance must be entered, i.e. there is no rubber banding preview as with single objects.
5. If the Fixed Distance box is not checked, the parallel object moves freely as you move the cursor, and the distance between the two objects is dynamically displayed in the Offset distance box as you move your cursor.

When the parallel object is in the desired location, click to place it. If you wish to repeat this process, press the Space Bar to repeat previous commands.

Lesson 9: Using Line Types

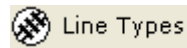

There are over 70 custom line types - scroll down to see them all!

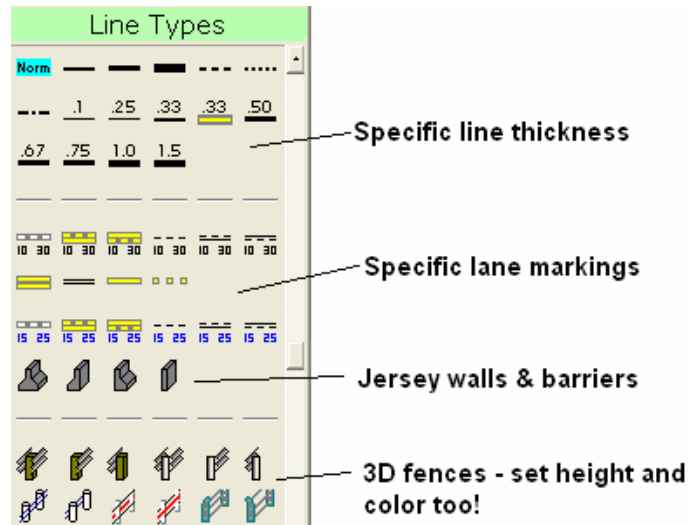

1.) You can change an existing line(s) by first selecting the line(s), then click on the line type you wish to change it into from the Line Types icon menu.

2.) Or you can draw using a selected line type. First select the line type off the Line Types menu. (You will see a small "T" appear in the properties rectangular box at the top showing you set a line type.) Then use any of the line or curve drawing commands. (Click the Norm button to reset back to a regular line type.)

EXERCISE:

- 1) OPEN DRAWING in files called "3d Traffic Fatality"
- 2) Now experiment with changing line types and adding new ones:
- 3) Select northern edge of road and then select a fence Line Type from the toolbox.
- 4) Select another Line Type, like a dashed type or Railroad tracks.
- 5) Now go back to Quick Pick on the Toolbox and use the line or curve drawing tools to draw with the new line type.
- 6) On the Line Type toolbox, select the Norm button to return to a normal, solid line type. Save your drawing.
- 7) Practice "breaking" a Guard Rail or Fence line like a car had driven through it. Then view your drawing in 3D by pressing the 3D button.

TIP: You can select the line and then click the 3D Builder button on the speed bar and set an exact height for fence or guard rail.

The PROPERTIES icon display on the top speed bar shows any Line Setting you have turned on:



EXAMPLE:

- 1.) This shows that “SCENE” is your current layer
- 2.) The “T” lets you know you have a custom line type selected
- 3.) The “W” means you have set a custom line width set
- 4.) The “Norm” button restores to regular line type

Lesson 10: Easy Intersection



EASY INTERSECTION: Automated Intersection Builder

The **Easy Intersection** wizard allows you to create simple or complex intersections easily and quickly using this preview building screen then placing on the screen:

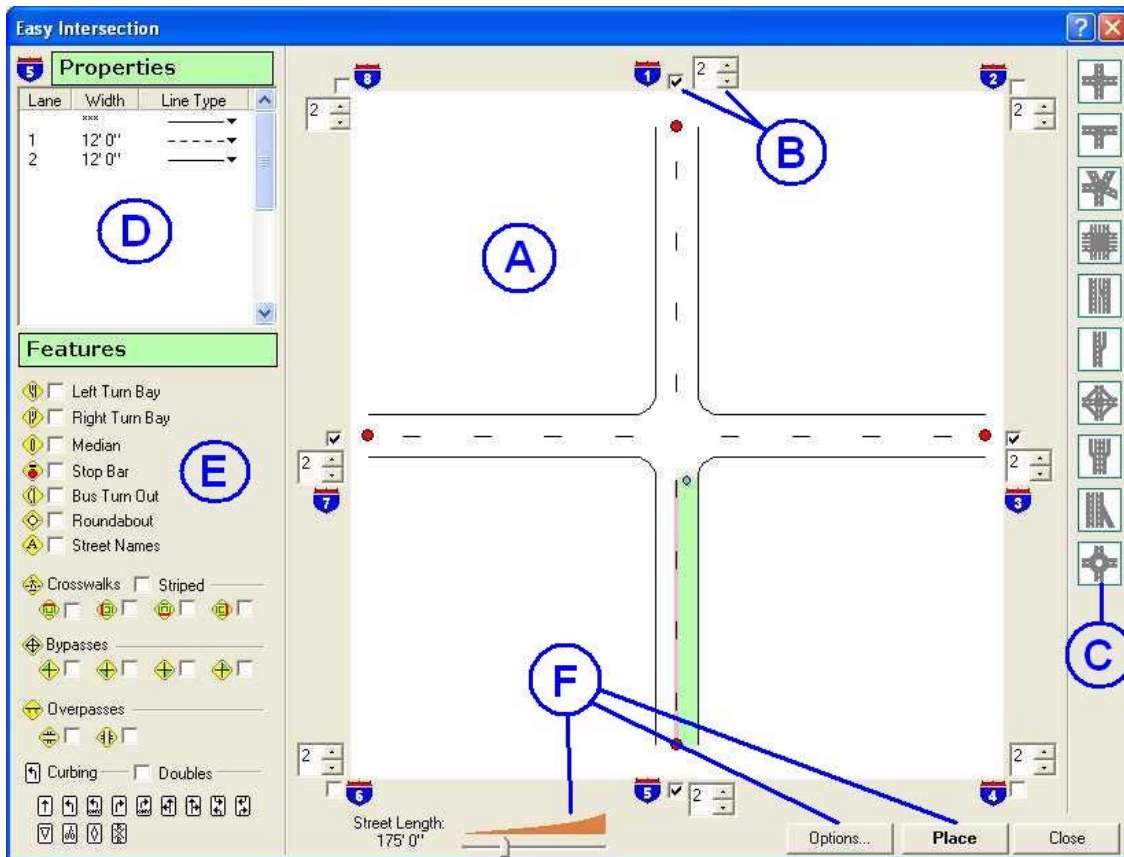

Letters Reference to sections in the above diagram:

- A.** Intersection drawing area preview
 - B.** Street selection check boxes with number of lanes (click to increase/decrease)
 - C.** Template guides (starting template format)
 - D.** Lane Properties (width and line type)
 - E.** Roadway Features (adding details shown)
 - F.** **Street length** slide bar, **Options** (settings) and **Place** inserts onto drawing screen
- The **red dots** are handles that can be used to grab the sides and angle the various sections of the intersection visually.
 - **Green shading** on the lower right lane shows that is the “selected lane” that you can set the Properties and Features for.

Easy Intersection Basics:

- 1) Each section of an intersection is referred to as a “**Street.**” The Interstate signs (1 thru 8) denote each of the streets.
- 2) Each “Street” is comprised of “**Lanes.**”
- 3) Whenever you’ve selected a “Lane” on a street, the interstate sign with that street number will be displayed in the “**Properties**” heading.
- 4) Click on a “Lane” and add any of the “**Features**” to it by checking the one or more of the “Feature” boxes.

Quick Steps:

- 1) Build the basic intersection layout, establishing streets and lanes. Or, you can pick one of the pre-built templates from the templates buttons on the right side of the dialog.
- 2) Change the rotation of a street moving your cursor while clicking on and holding down the red rotate handle.
- 3) Click on a lane to select it. When selected, a **lane will be highlighted green with a red highlight on the associated lane line.** The correct lane and lane line will be selected in the 'Properties' area of the dialog. There, you can change the lane width and line type.
- 4) Further modify the selected lane by checking the appropriate item from '**Features**' area of the dialog. Features include turn bays, medians, turn outs, roundabouts, street names, crosswalks, bypasses, and turn arrows. Features can be moved inside the lane with your cursor by clicking and holding down the blue rotate handle at the top of the lane.
- 5) When the intersection is complete, click on the “**Place**” button to place it in the drawing.

Tips and Tricks:

- 1) Clicking on the **Crosswalk** button located left of the description, "Crosswalks" will turn all four crosswalks on or off depending on the current state:



- 2) Clicking on the **Bypasses** button located left of the description, "Bypasses" will turn all four bypasses on or off depending on the current state:

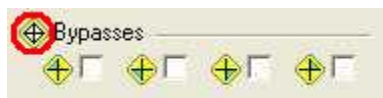

- 3) Holding down the **Shift key** while dragging the blue bypass handles will scale all the bypasses equally and simultaneously.

4) All Features placed in a lane can be moved back away from the intersection by grabbing the **Blue Move Handle** in the selected lane:

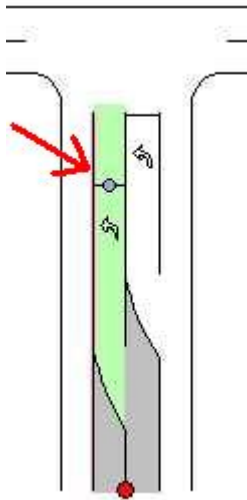

5) All Features can be selected use the **Right click** menu. Select the lane to add Features and Right click your mouse.

6) Use **Options** to change Lane, Crosswalk, Turn Bay, and Bus Turnout settings:



Using Easy Intersection:

1. Select Easy Intersection from the Left-Hand Toolbox.
2. Build the intersection you want to place in the diagram by:
 - a.) Check-marking the desired road segment boxes.
 - b.) Selecting on of the preset intersection templates.

3. Click the arrows to increase or decrease the number of lanes in each road segment:

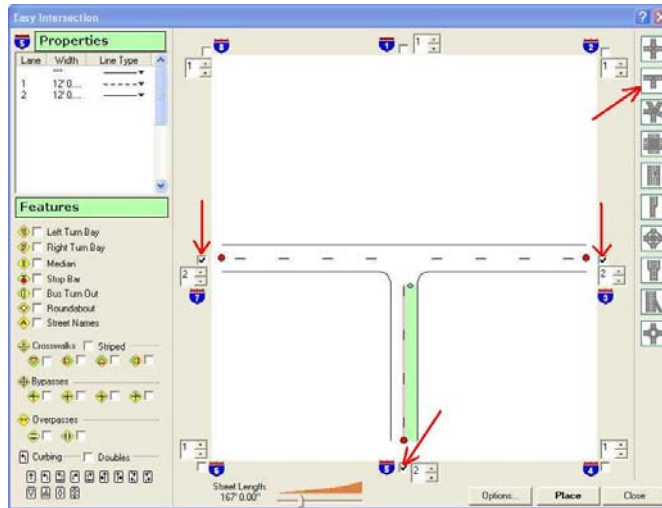

4. Move the Road Length slider to increase/decrease road segments:

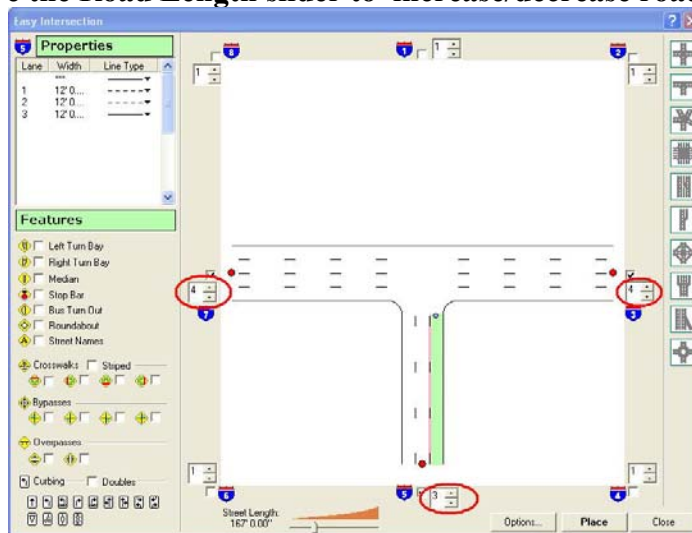

5. Click and hold on the red rotate handle to adjust the angle of a section:

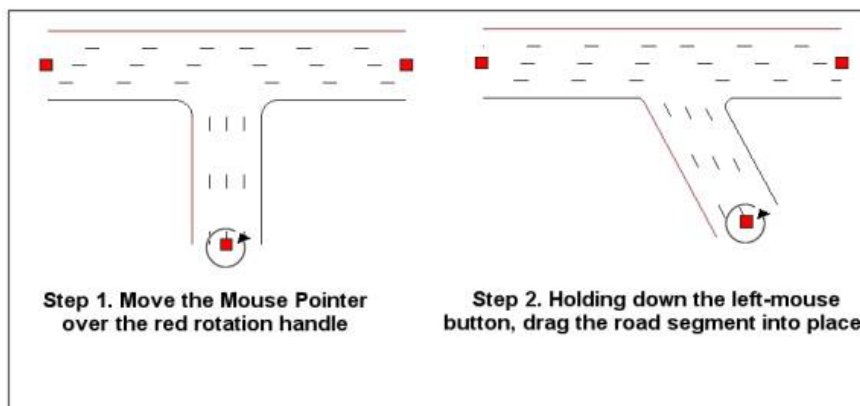

6. Click on the Place Intersection button to place the intersection on the drawing screen.

At this point you can further modify the intersection and change lane line types, add symbols, text, and dimensions. You can also use the edit/modify commands to stretch different segments of the intersection or break and cut out sections of the roads to show driveways or other openings.

Creating Intersections (Photo to Finish)

Photo of Intersection (“T” with school crossing):



“T” with school crossing created in the Easy Intersection dialog:

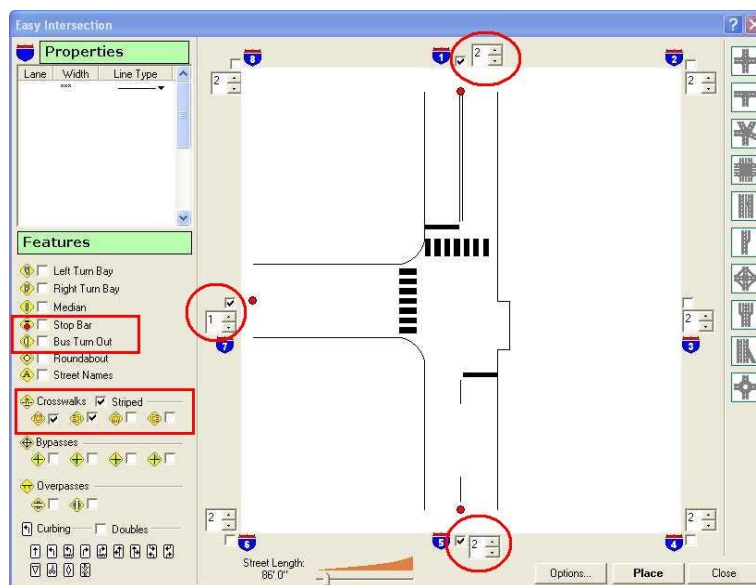

STEPS:

- 1) Established a “T” intersection by turning on “only” streets 5, 7, and 1.
- 2) The lanes are wide in this neighborhood, so open the Options dialog and set the “Default Lane Width” (15’).
- 3) For the driveway into the school parking lot use the “Bus Turn Out” feature. In Options set the Bus Turnout settings “Distance to Intersection” (0’), “Opening Length” (20’), “Curb Length” (20’), and “Width” (5’).
- 4) Select the first lane of street 5 and add a Bus Turn Out and Stop Bar.
- 5) Following the photo, add striped crosswalks to streets 7 and 1.
- 6) Change the lane line type of street 1 to a double center line from Properties.
- 7) Street 2 has no centerline, so make it a single lane with a width of 30’.
- 8) Place intersection on the drawing screen. Deleted the line of the opening into the school parking lot.

Finished intersection placed on drawing screen.

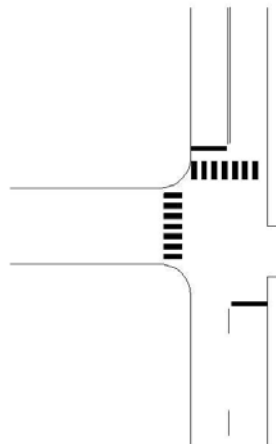
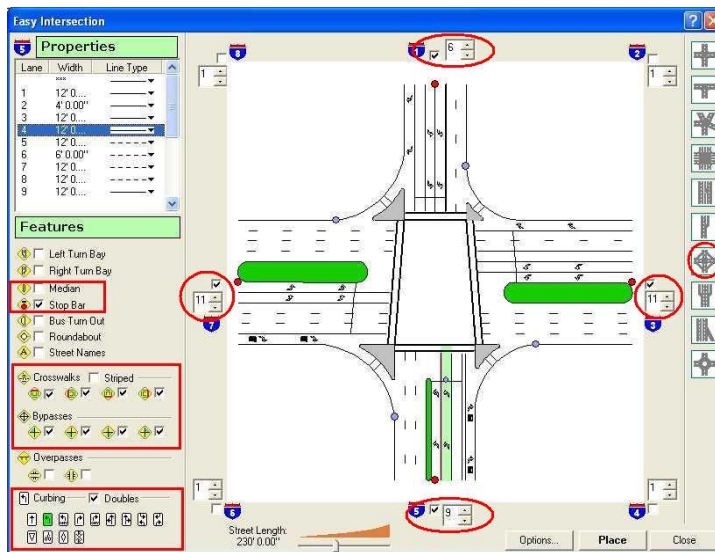

Photo of Intersection (4 Way with Bypasses):





STEPS:

- 1) Clicked on the “4 Way w/Bypasses” template.
- 2) Increased the number of lanes on each street to match the photo.
- 3) Changed the lane width in Properties where the medians are positioned to reflect their size in the photo.
- 4) Added medians from Features to the median lanes.
- 5) Selected each median and dragged them back by the blue move handle, back away from the intersection.
- 6) Added stop bars and turn arrows from Features. Doubled up all of the arrows.
- 7) Selected each lane with stop bars and arrows and moved them back to line up correctly with the median as seen in the photo.
- 8) Changed some of the lane lines to solid from Properties.
- 9) Clicked on the Place button to put the intersection on the drawing screen.
- 10) Once on the screen used the Trim/Extend command to trim some of the lane lines to the stop bars that were moved back away from the intersection.

Photo of Intersection (Reducer):



Reducer created with Easy Intersection dialog:

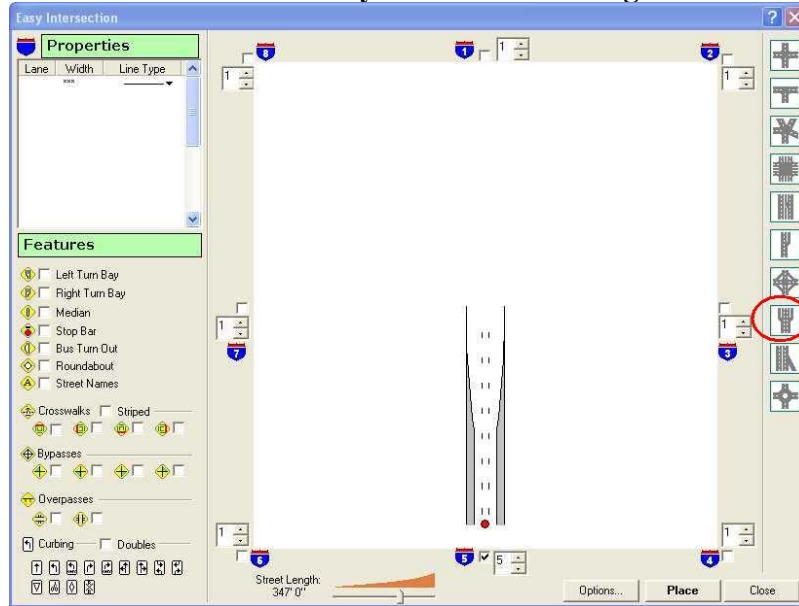

STEPS:

- 1) Picked the “5 Lane to 3 Lane Reducer” template.
- 2) The reducer is simply made up of 5 lanes with a left and right turn bay on the outer lanes to give the impression of a reduction in lanes.
- 3) In Options, set the Turn Bay, “Distance to Intersection” to 5’.
- 4) In Options, set the Turn Bay, “Opening Length” to 150’. This will elongate the turn bays making the change more gradual.
- 5) Place the reducer in the drawing.
- 6) Rotate the entire reducer to match the photo.
- 7) Extend or stretch the lane lines to match the photo.
- 8) Lane lines line type can be changed using the Line Types menu on the Left Toolbox in the diagram program or from Properties in the Easy Intersection dialog.

Reducer placed and rotated with Lane lines changed, stretched, and extended:

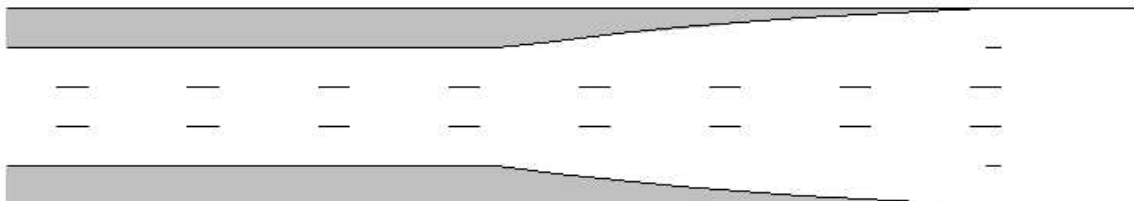

Lesson 11: Easy Lines

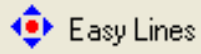

You can also use the Easy Lines method to draw lines to **actual measurements** for the walls of a building, **vectors** to show angle of departure, etc. In “Normal Mode” Easy Lines lets you draw a continuous line by entering a **direction** and **distance** for each one.

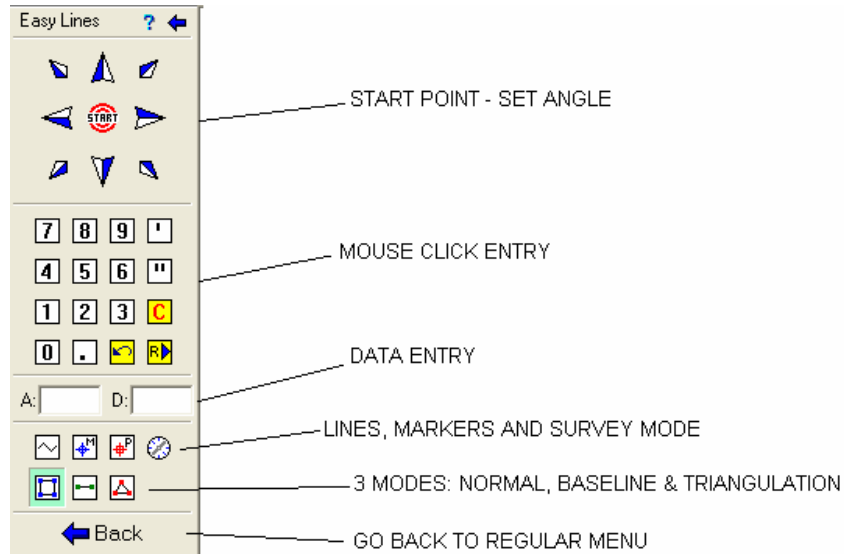

There are **3 MODES: Normal, Baseline and Triangulation**, with any of them you must first click the **bulls-eye start button** to pick your starting point.

For this exercise we will just use the **Normal Mode**  that allows an Angle-Distance input. (We will cover the Baseline and Triangulation options in a later section.)

The angle and distance input can be input on either your keyboard or use the built in keypad and your mouse.

EXERCISE:

1. Open **NEW** drawing and name it “House 1” (Units “feet & Inches”, precision 0)
2. Bring up the Easy Lines toolbox by selecting it from the left-hand toolbox
3. Check it is in Normal Mode
4. To establish the starting point, click on the Bulls-Eye icon in the center of the Easy Lines toolbox
5. Click near in the lower left of the screen for the starting point of the first line.
6. Click on the up (N) direction arrow on the Easy Lines Toolbox.
7. Click 34’2” on the numeric keypad on the toolbox.
8. Click on the Line draw button in the lower-left of the toolbox and the line is drawn on the screen.
9. Now Click the right (E) arrow to establish a new direction and type the length for the next line, 37’1” in this example shown on following page.

You can continue to draw connected lines as if you were measuring around an entire building this way as shown in this example:

Easy Lines Exercise

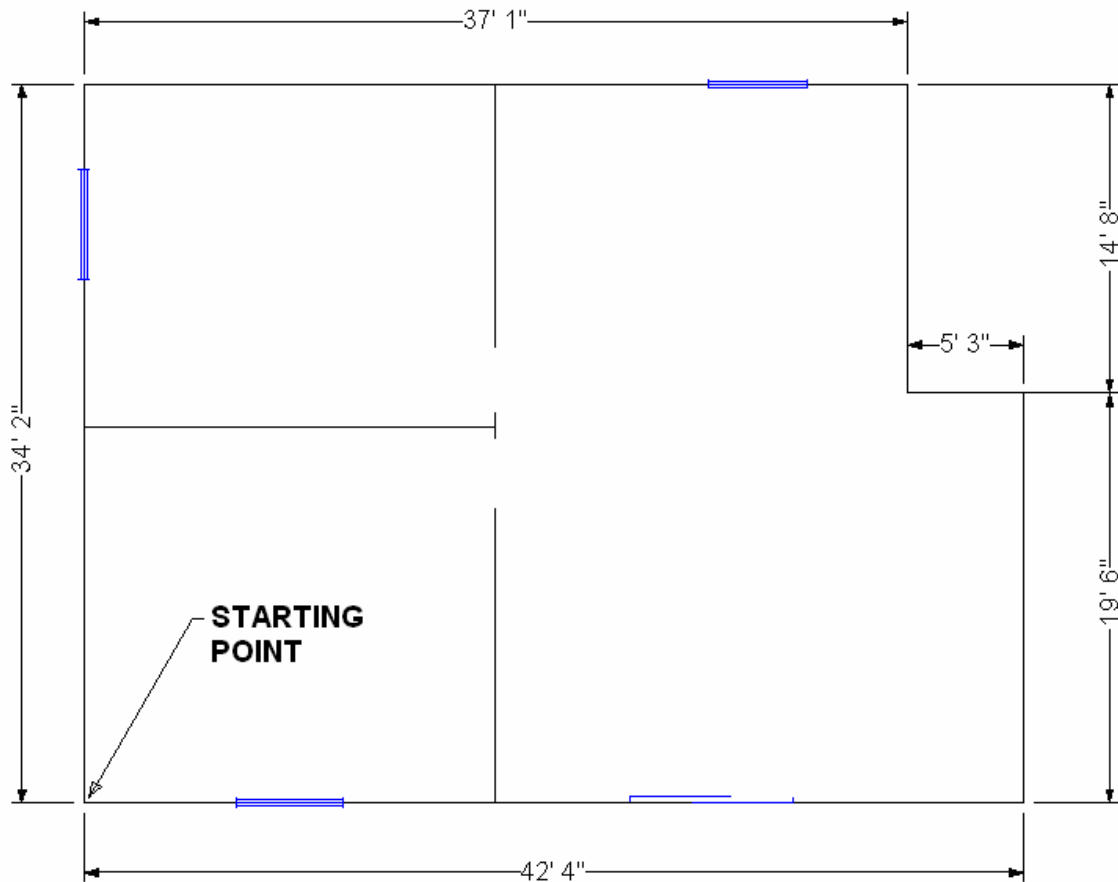

You can use any of the View or Scroll Bar commands while you are drawing lines so you can move around where you are working.

If you wish to start drawing lines or markers from a new starting pointing, click on the Bull's Eye icon in the middle of the angle arrows. This allows you to select a new Start Point for the next line segment.

If the angle of a line you wish to draw is not represented by one of the arrow keys, simply click once inside the Angle box on the toolbox and then enter the desired angle from the numeric keypad (or the regular keyboard).

Once you click inside the Angle or Distance box, select the C button on the toolbox to Clear the value that is currently displayed in that box.

The undo arrow back arrow removes the last entry. The "R" button repeats the same angle and distance as previously entered.



Baseline Mode: click bulls-eye to start point on screen, then enter Distance 1 and Distance 2, the first is the distance along the baseline and the second is the offset distance. The “Flip” button is same as negative value. This mode allows only red (permanent) or blue (temporary) markers - no lines.



Triangulation Mode: click bulls-eye and select 2 triangulation points on screen. Enter Distance 1 and Distance 2, the first is the distance from the 1st triangulation point and Distance 2 the distance from the 2nd point. Flip is the intersection on the opposite side and you can only place markers in this mode also.

EZ Baseline - Baseline Easy Lines is used to set points (markers) based on baseline measuring procedures. When you switch to EZ Baseline the compass arrows change to the color green so you know you are in Baseline mode. The field changes to D1 & D2 for Distance from first marker and Distance from 2nd marker. To place points using the Baseline Easy Lines Method:

Click on the bull’s eye to set the Base Point.

Click on the screen to set a base starting point (green target appears).

After setting the base point, you will be prompted to show the direction of the baseline by moving your mouse in desired direction and click.

(Note: If you want to set the angle other than horizontal/vertical, then hold Ctrl key down and use the bottom Angle display to set desired angle.)

Click the number pad and enter the first distance (D1). This is the distance along the baseline from the base point. (If you enter a negative number for D1 the distance will be along the baseline in the opposite direction.)

Click in the second field (D2), or press the Tab key. The distance you enter here is the distance perpendicular (offset) to the baseline.

Click on one of the marker buttons, either the temporary (blue) marker or the permanent (red) marker. Repeat to place as many markers as you need.

Once the markers are placed in the drawing you can snap lines or vehicles to them so they are placed exactly at the desired location.

Tip: If the marker is placed on the wrong side of the baseline then click on the "Flip" button and pick the marker again. It will place the marker on the opposite side of the baseline. Once you select the Flip feature it will stay selected until you click on it again.

EZ Triangulation - With triangulation measurements, two reference points are needed. Other points are located as being at the intersection of 2 lines based on radial measurements.

When you switch to EZ Triangulation you'll notice the color of the arrows changes to red so you know which mode you are using. Entry fields are D1 (distance from point 1) and D2 (distance from point 2):

EXERCISE: Triangulation Easy Lines Method:

Click on the bull's eye to set the reference points.

Click or snap on the screen to set your first reference point. Click on the screen to set your second base point (note distance on bottom right).

The base points will be shown as magenta colored triangles with cross hairs inside them. Click on the number pad to enter the first distance (D1:). This is the length of the radius from the first reference point to the marker.

Click in, or tab to the second field (D2:). This is the length of the radius from the second reference point to the marker.

Now pick a marker, either a temporary (blue) marker or a permanent (red) marker. Where the two radii intersect (entered above) is where your marker will be placed. If the marker is on the wrong side of the baseline then click on the "Flip" button and select the marker again. This will place the marker on the opposite side of the reference points. Once you select the Flip feature it will stay selected until you click on it again.

Repeat steps 6 through 8 to place the remaining points.

Lesson 12: Easy Builder & Auto-dimensions

This toolbox lets you select a basic building shape and enter the length of each wall. You can even select to automatically dimension the sides of the building and place text.

EXERCISE:

1. Continuing with the same drawing file "Road 1":
2. Select the Easy Builder icon from the left-hand toolbox.
3. Select a building shape.
4. To specify the length of the walls, you can either enter measurements in the text entry boxes or use the mouse in the preview window to drag the walls to a new size.
5. Click the Mirror and Rotate buttons on the right side of the toolbox to adjust the orientation of the building.
6. You can automatically dimension all of the walls by checking the Auto Dimension box in the lower-left of the toolbox. Click the big or small letter A button to change the size of the text.
7. When the building looks exactly the way you want it, click the Place Building button and click in the diagram where you want it. Save drawing.

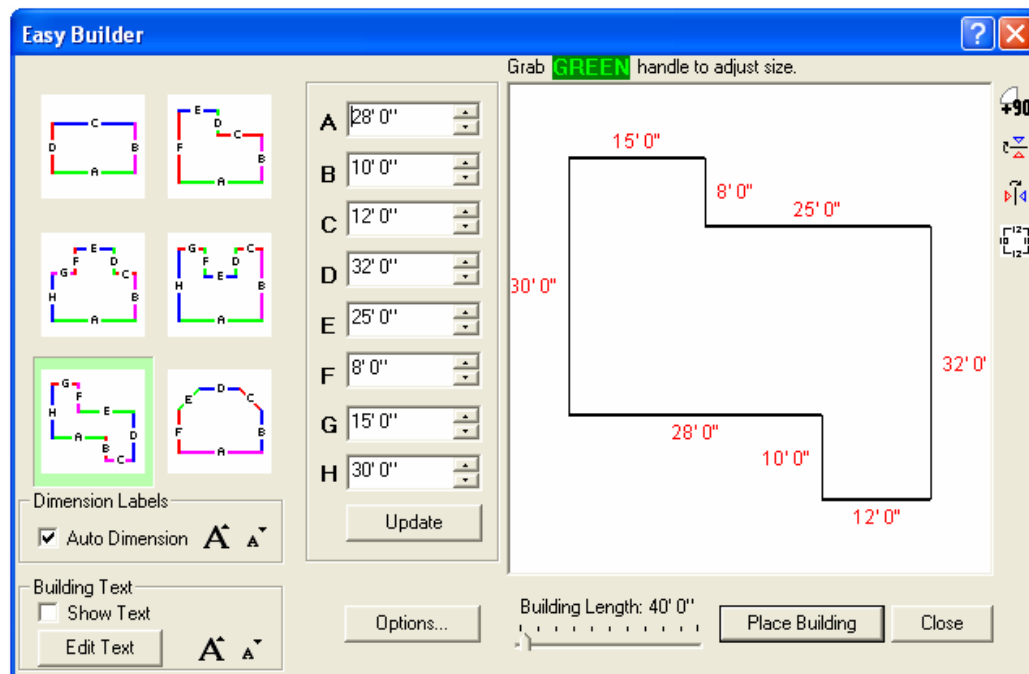

Lesson 13: Adding & Editing TEXT



The **Quick TEXT** feature is used to label objects and place text in the diagram. It lets you adjust the height, center it, make it bold, repeat and add an arrow leader.

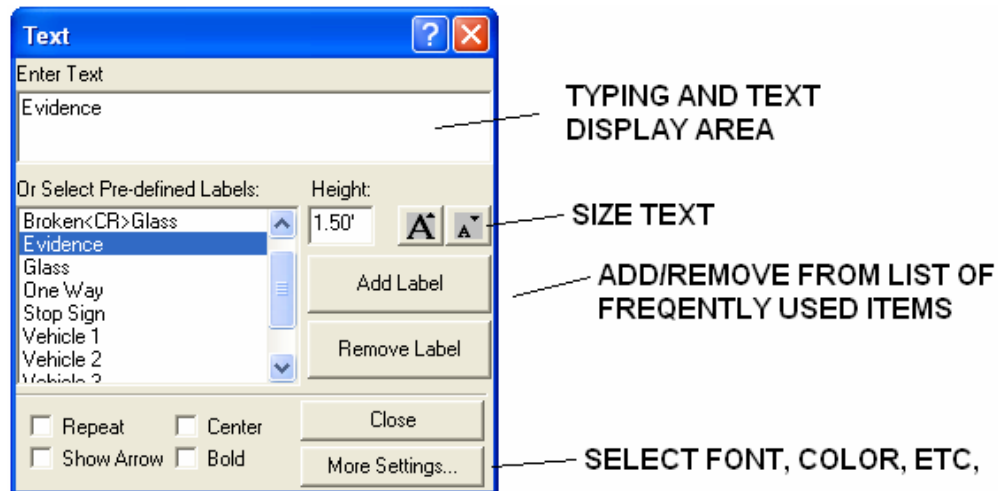

1. Select the **Quick TEXT** command (“Floating Toolboxes” can be moved.)
2. Enter the desired text in the text entry box or click on one of the pre-defined labels to place it. (You can add/remove labels to customize your frequently used text list.)
3. Move the cursor back into the drawing window to see an outline box showing the preview size of the text. To **adjust its size**, repeatedly click the big **A** or small **A** buttons on the toolbox.
4. Click once to anchor the text, move the cursor to rotate it to the desired angle, click again to finish it. Turn **Ortho Angle 0 on for horizontal or vertical placement**.
5. Turn on “**Show Arrow**” to place a leader and add text with a leader.
6. Turn on “**Repeat**” if you want to place the same text in several locations.

To **EDIT TEXT** that has already been placed:

- click to select text, then select the Edit command on the left-hand toolbar. The text is shown in the Text Edit screen so it can now be edited – be sure to click OK to complete and apply the changes.

EXERCISE: Placing & Editing Text on “House 1” drawing from earlier exercise:

Use the Quick Label command to place text in the diagram. Practice with some horizontal and some rotated. **Save your Drawing!**



Using Bubble Text:

The Diagram Program allows you to place Bubble Text “**markers**” to **draw** attention to witness, sample, photo, evidence, and other items located in your diagram

The Bubble Text command is found on the left-hand toolbox of the Quick Pick menu.

Clicking a marker icon displays it in the preview window where it can be edited.

Clicking on the “Larger and Smaller” text icons changes the text height. The color of the bubble may be changed using the Color Palette button. You are also given the option to bold and to add Arrow leaders to point at a specific object or point in the diagram.

EXERCISE

1. Select the Bubble Text command from the left-hand toolbox.
2. When the Bubble Text toolbox appears, select the desired bubble type.
3. Click on the arrow buttons to enter the number (or click in the text field and type in the numbers).
4. Move your mouse pointer into the Drawing Screen and click the left-mouse button to place the tip of the arrow of the bubble label.
5. Move your mouse pointer to position the bubble text to the desired location. As long as the bubble label dialog box is displayed you can continue to place additional bubbles. Click “close” to finish placing bubbles.

Tip: Like all “floating toolboxes” you can drag the bubble label toolbox out of the way if you need to.



Lesson 14: Dimensions

The Quick Dimension tool lets you place a dimension between any points on which you click or snap. You can also use the “single-click” mode to quickly dimension lines such as the walls of a building.

The program measures the objects and generates the dimension value for you automatically. This is why it is very important that you make your drawing to scale.

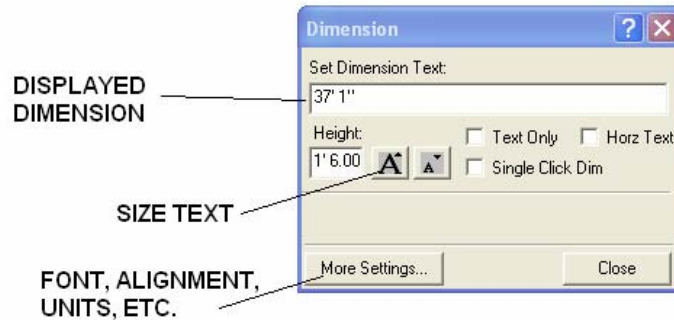

EXERCISE:

If you are dimensioning to existing points, like the corner points of the walls of a building, make sure Auto-snap is turned On.

1. Select the Quick Dimension command from the left-hand toolbox.
2. Click on the first point of the object to dimension; click again on the second point. When dimensioning a wall, be sure to snap exactly to the corner points.
3. Move the cursor away from the wall and notice an outline of the dimension.
4. Click the big A or small A buttons on the toolbox to adjust the text height.
5. Click a final time to position the dimension text and dimension lines.
6. Continue to place dimensions in this manner by clicking on two new points. Also try the “single click” mode to dimension any line by just clicking once anywhere along the line.
7. Once a dimension is placed in the diagram, it can easily be modified:
 - Click on a dimension to select it.
 - Select the Edit command from the left-hand toolbar.

Select any of the options to adjust the position, size, etc. and even font and color if you look in the More Settings. **TIP:** the **Slide Text** feature allows you to move it outside of the dimension lines which is very helpful in situations where there is not enough space.

Click OK to finish the changes.

Tip: When you place a dimension the program calculates the distance between the points exactly the distance it was drawn. Occasionally you may want to overwrite this or add a text note; this can be done by typing in the display area of the Text dialog box.

Lesson 15: Placing Symbols

The program has a large number of pre-drawn symbols and several options to help you quickly place symbols in your diagram.

Click on Symbols on the left-hand toolbox. This brings up the **Symbol Manager**.

Select from one of the Symbol Groups using the pull-down arrow at the top of the toolbox. **These symbol groups include: Crash, Crime, Marine and My Symbols.**

The named buttons at the top of the toolbox represent the various **Symbol categories**: Quick Pick, Landscape, Bodies, Vehicles, etc. and some even have **sub-categories below** each with their **own groups of symbols**.

1. Click once on one of the symbols shown in the symbol preview window to select it.
2. Move the cursor back into the drawing window and notice a preview of the symbol is now attached to the cursor. You do not have to keep holding down the mouse button.
3. Each symbol needs **TWO clicks to place them**. The first mouse click is the **Pivot or the Anchor Point** where it inserts; the **second mouse** click allows you to **Rotate** about the pivot point so you can place the symbol at the desired angle.

Once you select a symbol from the Symbol Manager, there are also several options offered that allow you make changes upon placement:

- The **Mirror** buttons flip the symbol - try this with a non-symmetrical shape.
- To change a symbol's **Color**, select it from the Symbol Manager and click the color palette button at the bottom of the toolbox.
- (Click the color palette button again to return to using the default symbol colors for new symbols to be placed.)
- All the symbols were initially drawn to represent an **accurate real life scale** but occasionally you may need to modify. To change a symbol's size as you insert it, select symbol and then click the Dynamic Symbol Scale button on the bottom. (Click in the drawing to anchor the symbol then move the cursor and you will see it scale dynamically as you move your mouse). Click when it is the desired size.
- Most symbols are a collection of objects such as lines, arcs, text, etc. that are "**grouped together**" into one object making it easy to move or rotate.
- To edit a symbol you must first **Explode** it but this will reduce it back to individual lines and objects. In most cases it also makes any 3D object 2D, **so do not use** this command unless you are experienced.

Lesson 16: Placing Bodies



Use the Bodies icon from the QuickPick tool box to place a body in a drawing by selecting a gender, height, build type, and view:

EXERCISE:

- 1.) Select the gender, height, build and the basic body position in the dialog box.
- 2.) Once the body is placed you can modify the position and can add color which will carry over to the 3D view also.
- 3.) To bend an arm, leg, etc. Select part(s) using shift and left mouse to pick them all. Move the pivot point to a joint area then use the rotate handle to rotate into place. Can remove or swap parts between body symbols too.
- 4.) SAVE your drawing.
- 5.) **There are several specific Pre-Posed body symbols in the Symbol Library that you can also use.**

Lesson 17: Hatch Patterns and Fills

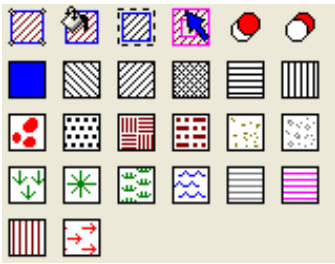



HATCH and FILL patterns: allow you to depict several of types of surfaces or debris, damaged areas, blood, fluids, vegetation, water, etc.

 Trace a Boundary command to draw a hatch pattern or solid fill within an area that you specify by clicking manually to define the outline.

 Pick Area hatch command to add a hatch pattern or solid fill to simple closed objects. (DO NOT pick too complex an area or it will not work and may close diagram.) Must be a closed shape so use snaps when drawing to avoid leaving gaps in the object or outline.

 Window Hatch command to add a hatch pattern or solid fill to closed geometric shapes contained in the crossing window. (Can be handy when you want to add a hatch or fill to an object that exists inside another, but do not want to add the pattern to both.)

 Hatch Selected is also good for doing more any closed shapes. The selection tools that come up across the top of the drawing area let you pick: the Select Adjoining option button  is very useful for more complex closed shapes like a median, parking lot, fluid/debris pattern, etc.

 Red/White circles are the send to back/bring to front. The patterns and fill are opaque and may cover part of your lines so sent them to the back to see your lines again.

TIPS: ZOOM IN so you are close while working for precision and for complex shapes or those that are not perfectly closed, use the manual trace.

- It is best to put your hatch/fill on a separate layer so you can turn it on/off or lock so it does cover any of your drawing details. Use lighter colors for better readability. (More hatch patterns and hatch setting options are available in the Pull-down menu when you select one of the hatch commands.)

Example of hatch used in a diagram:

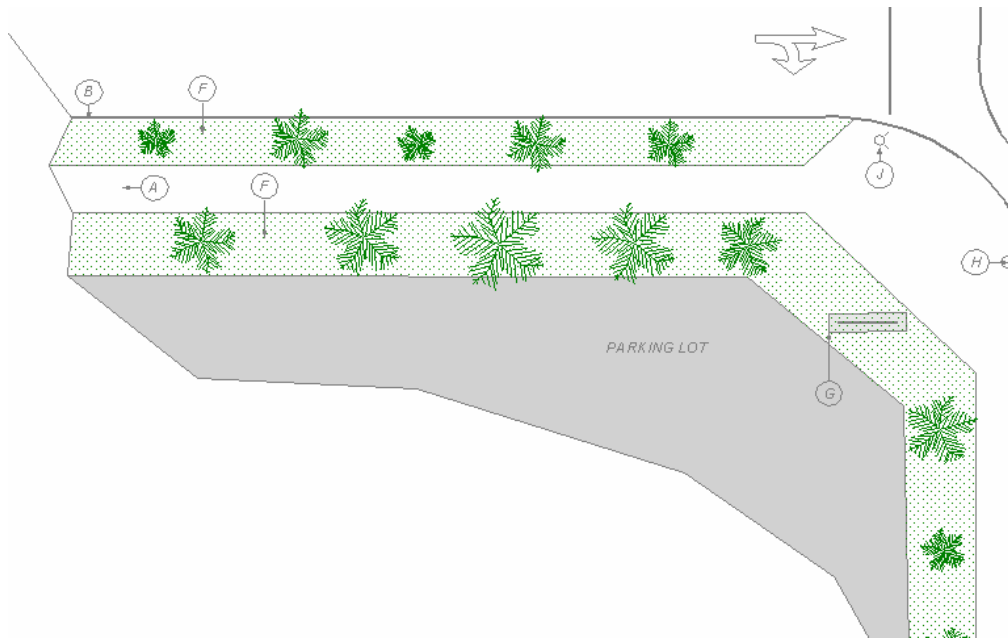

EXERCISE:

Experiment using the different Hatch/Fill commands and try the different options available. Place text on top and then practice bring to front/send to back options.

Lesson 18: Templates

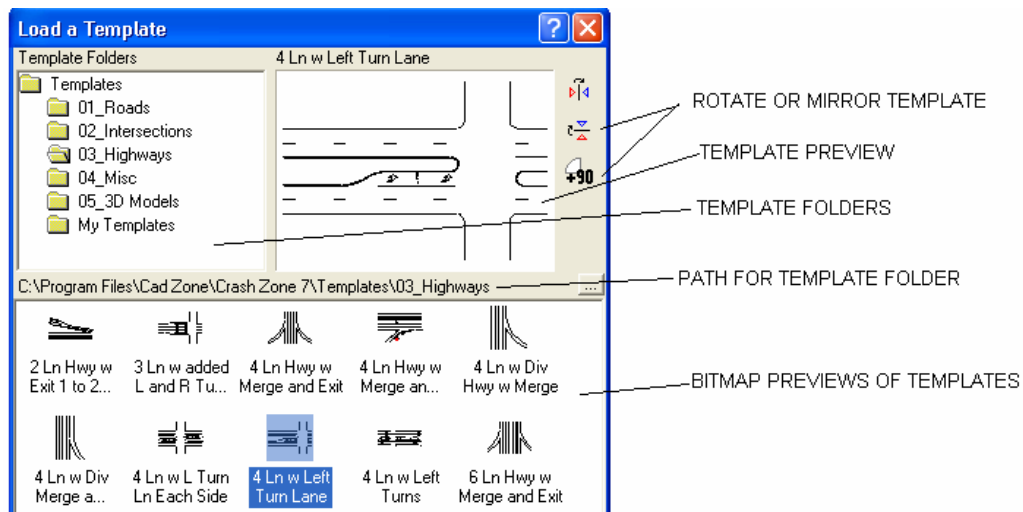

Customizable template library pre-made ones you can modify or add your own. You can import AutoCAD or other CAD drawings (dxf or dwg) from engineering drawings to build template library of your common intersections. You can create a new template folder in Windows file explorer to store your different categories for easy retrieval. Default save path: C:\Documents and Settings\Anna Ristau\My Documents\My Cad Zone\Templates\My Templates

Save Template < will bring up the following:

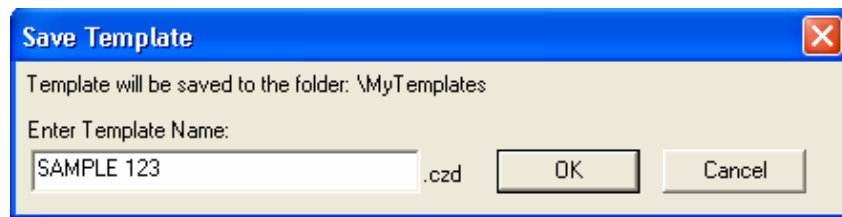

Just type in a template name and all objects the drawing objects will be saved as a template in the folder called “My Templates” with preview and name you assigned it. To insert a template: select, click Place and then click to place in diagram.

EXERCISE:

- 1.) Insert existing template into drawing and try the rotate command in preview.
- 2.) Use one of your own drawings or an existing drawing and save as a template.
- 3.) Go into Window Explorer to see where they are stored (shown above). You can move and delete them from this location only.

Lesson 19: Adding a Form (Border) and Printing

Use the Forms feature to automatically place a rectangular border around your diagram.

EXERCISE:

Select one of the Forms feature from the lower right-hand toolbox.

Click to try each of the forms from mid-section: the two Custom forms, diagram and evidence sheet, or the landscape/portrait. (The bottom two are California State accident forms borders.)

Click on the “X” in the text fields then the Edit button to add your text.

TIP: Forms can be customized by overwriting existing ones but this is best left for more advanced users. A quicker and easier way to make a custom form is to save it as a symbol instead.

Printing and Print Tiling

When you are ready to print your diagram, click the Printer icon on the Speed bar. There are three basic ways to determine how your diagram will be printed out:

Fit to Paper fits the entire diagram on a single sheet of paper and displays scale.

Current View prints the current zoomed view of the diagram on a single sheet.

Scale allows entering an exact scale to use for printing. This scale is entered in the format: X inches on paper = Y feet in the real world

Other options include the ability to change the paper orientation from portrait to landscape, add page “stamps”, change line widths to be bolder, and Setup your printer.

Two options at the bottom of the toolbox help adjust the rotation of text on the print. Some printers seem to rotate all text in the diagram by 90°. If you notice this happening, select Text Rotate Adjust and see if this solves the problem.

Printing Tiling

When printing diagrams to an exact scale, it is possible to specify a scale that does not allow the diagram to fit on one sheet of paper. In this case the program automatically uses Print Tiling to divide the drawing up so it can be printed on multiple sheets. Which can then be taped together to make a large drawing if a large scale plotter is not available.

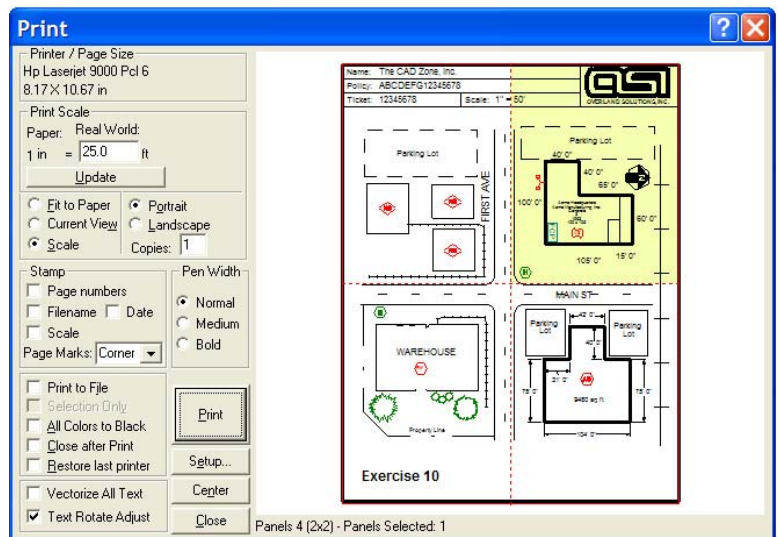

Lesson 20: File Basics

Save and Open files

Open a backup “. BAK” file

Merge a file

Importing Bitmaps

Exporting file types: Vector and Raster format options

A.) OPEN existing drawing, the .CZD (CAD Zone Drawing) format is the default. To open other file formats, click the “files of type” down arrow to see other options.

You can select AutoCAD (.DWG) files, .DXF files, PocketZone (CAD Zone data collector), Laser Technology RAW files, ASCII Coordinate data from total stations, etc.

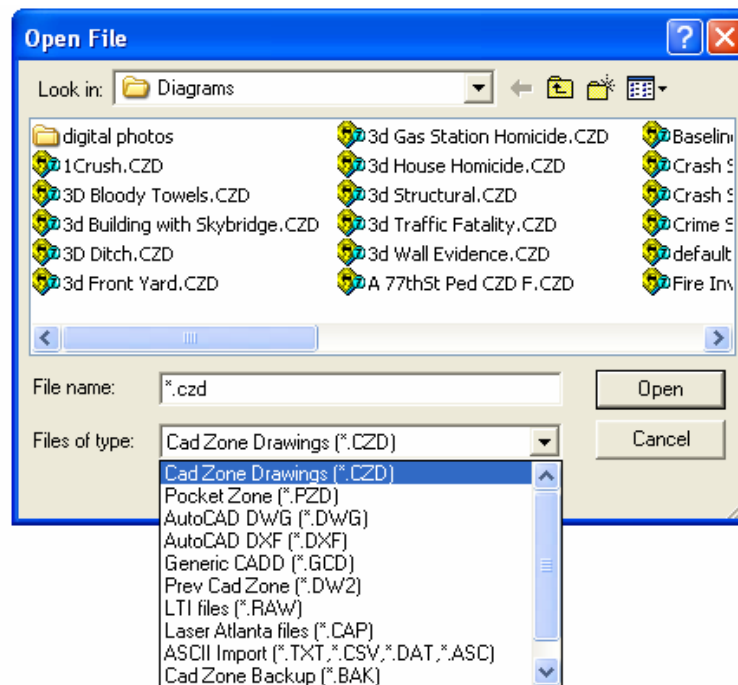

If necessary, change the path and drive in order to locate the file you wish to open. You can click on the “Open” button to browse various folders to find your files.

In the list window, double-click the file name, or select the file name and click Open.

The program default path for the DIAGRAMS folder is:

C:\Documents and Settings\Your Name\My Documents\My Cad Zone\Diagrams

Version 7.4 has a new pathing set up options to view these:

Under the UTILITIES pull-down select SETTINGS then the PATHS tab. This allows you to create folders elsewhere and set paths.

B.) EMERGENCY BACKUP

In case you forget to perform a regular save and something goes wrong, a named drawing will do an automatic backup every 5 minutes to the job .BAK file.

If this happens, shut down the CAD Zone program WITHOUT saving (if it is not already closed). Find the .BAK file that corresponded with your drawing name, rename to something else (i.e. add a “2” to it) and then change the .BAK to a .CZD extension.

Now open The CAD Zone program and open the renamed drawing. You should not have lost more than 5 minutes worth of work.

Opening a .BAK back up file: Click on My Computer icon to view your files and go to the directory where your files are. You should see your original and back up files:

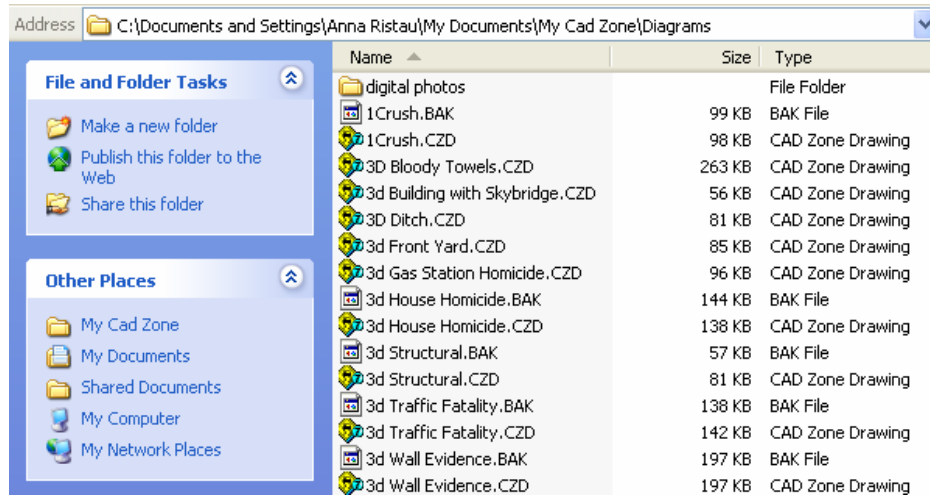

C.) Merging and Aligning 2 Drawings or Jobs

Main uses: for adding new evidence to existing diagrams, adding new scene information to a template of an intersection or adding to your scene at a later date.

Merging two drawings each containing 2 common points (or a common line) that will be used to align the two drawings together. (Tip: use a wall, top of a fire hydrant, manhole center, survey marker, etc.)

Open your first drawing which will become your BASE drawing.

Merge your second drawing (File > Merge) into your base drawing but be sure you place it off to one side, away from your base drawing.

Now select the merged drawing or pick specific objects you want to Align onto your base drawing. You can use a window to select all of it. (Turn on the Auto Snap option for the next steps).

Now run the Align command by either typing “AG” or go to the Edit/Modify drop down menu to, "Align Common Points".

It prompts you to “Pick common (pivot) point of the first selected objects.” So snap to the first common point on your merged drawing. Next click on the second common point on this same drawing.

Next, snap to the first corresponding common point on the base diagram (this becomes your pivot point) now snap to your second common point on your base to complete the alignment.

(TIP: You can also follow the instructions on the command line when using this command to help you keep track of your steps and it will prompt you.)

D.) Importing Bitmaps



DIGITAL IMAGES: to add your digital photos (jpg, bmp or wmf) or air and satellite photos that you can even trace and draw over.

To place an image in your drawing screen, you first must click 2 points to define a “window frame” where your image will be inserted. Then browse to find the image you wish to insert. Images can be easily moved and scaled afterwards. (See how to set to a scale in the advanced instructions.)

TIP: insert the image on a separate layer (or move to a separate layer after) so you can LOCK the layer or turn the image on/off. Use the Send to Back/Bring to Front icons on the Quick Pick tools if the image hides some of your drawing lines.

E.) Exporting Images: Vector vs. Raster

You can print from CAD Zone but sometimes you may need to send a drawing file to someone or save to put into a Word document. We give you several options including a PDF format save (ADOBE) that most anyone can open. The formats under Save give you the nicest and sharpest images:

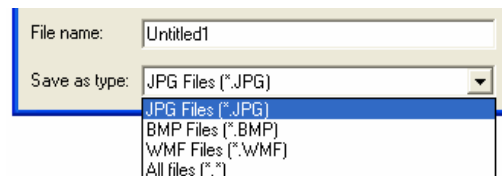
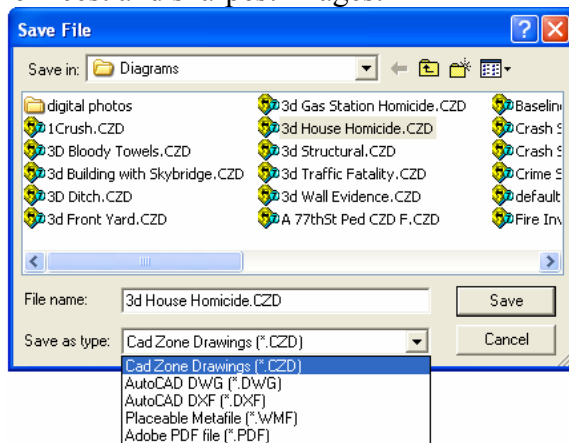

The Raster save formats are under the File pull-down to the “Export Image” but the .JPG and the .BMP do not provide crisp lines or print as clearly as other formats will.

Lesson 21: 3D Basics

Creating a 3D Diagram: CAD Zone makes it easy to complete a 3D scene by doing most of the work for you. Most objects like symbols, line types, and bodies are converted to 3D automatically. To see other objects in the 3D view, like a wall, simply assign them a height, an elevation if needed, and a color. Then launch the 3D Viewer to see the rendered model.

Lesson 31: 3D Tools and Functions

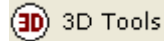

3D View Mode, Snap Shot Manager, 3D Builder, Vertical Wall Evidence, Easy Doors/Windows and Easy Roof Builder

Symbol Align to a Surface
Symbol Align to Points and a Reset

Easy Surface (generate 3D surfaces) and Easy Surface settings options

Slope Calculator and Ground Level Adjust (for 3D only)

Profile Generator and Settings for Profile Grid Spacing



3D BUILDER

The 3D Builder tool differentiates between Line objects, Points, and Symbols. Different options appear in the dialog box depending on what type of object is selected.

Line Objects - When Line objects are selected 3D builder prompts for Wall Height (Extrusion) and Elevation.

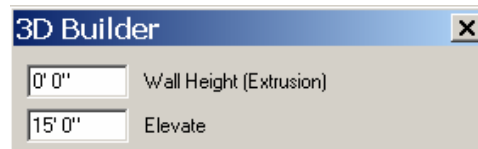

Points - When Points are selected, you are prompted for an elevation height only. The Wall Height option becomes inactive.

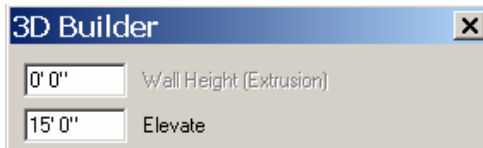

Symbols - When Symbols are selected 3D Builder prompts for Symbol Height and Elevation. You can now set the individual height of a symbol. For example you may set a tree's elevation to 100 ft tall, an SUV be 5'3" tall and so on. When you set a 3D height to

an object it will not affect the length or width of the symbol preventing it from becoming skewed out of shape to provide you with an accurate representation.

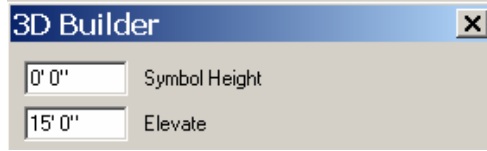

Lesson 22: Making 3D Surfaces



EASY SURFACE tools

Use surfaces to create 3D road surfaces, landscapes and other sloped surfaces. Easy Surface uses a special triangulated (TIN) boundary fill which is not to be confused with hatch patterns which are only 2D. To create a 3D surface you select or snap to 3D points and 3D line work. CAD Zone provides a unique method of generating accurate 3D surfaces that require fewer points and allows better control.

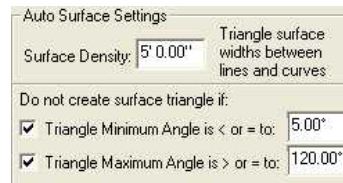

3D SYMBOL ALIGN (to Plane)

This command allows you to align symbols onto a 3D Surface plane. To do this first select the symbol then 3D Symbol Align (to Plane) icon button. Then one click near symbol onto the surface to align on to – be sure to turn OFF SNAPS first.

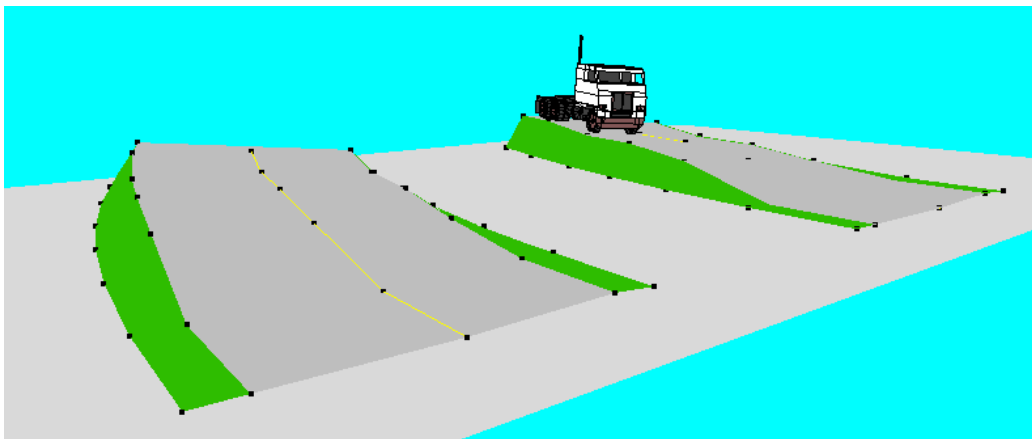



3D SYMBOL ALIGN FREE

This command allows you to align symbols to 3 points with elevation that defines an imaginary 3D plane that the vehicle is aligned to. (Can shoot the bottom of the vehicle to get 3 points or calculate and generate manual points if needed). This is useful when a vehicle is not sitting on a surface (i.e. it is stuck upright in a ditch or against an object, is air borne, or rolling and can also be used to depict a motorcycle doing a wheelie or going over on its' side).

First select the symbol to align then go to the 3D Tools to the 3D Symbol Align Free button. Check to be sure your SNAPS are ON then snap to the 3 points defining the imaginary plane the object is on.



RESET places the symbol back to zero ground plane.

Lesson 23: 3-D Viewer (3D Rendering)



3D Viewer (activated with licensed 3D version). This takes you from your 2D diagram into a dynamic 3D view. Use the camera, target, arrow keys and your mouse to maneuver within the 3D view. These views can be instantly saved as jpg files using the camera button, then inserted into your drawing, a document, printed separately or make a slide show animation.



Snap Shot Manager stores any 3D images saved that were taken in the 3D Viewer. Provides a quick Animate Preview and the ability to Place the images right into your diagram using the Place button.

These images are stored in the SNAPSHOTS folder and stored in this default folder (or set your own destination folder in the program path Setting:

C:\Documents and Settings\Anna Ristau\My Documents\My Cad Zone\SnapShots

3D VIEWER SPEED BAR COMMANDS:



2-D Bird's Eye view of your scene (move camera and target manually)



3D VIEWING PREFERENCE SETTING: wire frame, step distance, background colors, turn ground surface on/off and other VERY important settings.

 Takes you BACK to your 2D view

 10' 8" CAMERA Height (where you are viewing from)

 1' 4" TARGET Height (where you are looking toward)

 SNAP SHOT – saves your current 3D view as a JPG file (Turn off birds-eye preview box unless you want it in the picture.)

 Top and Side Views

 Perspective Views

Preferences Toolbox

The Preferences toolbox is where you manipulate the settings used by 3D Viewer:

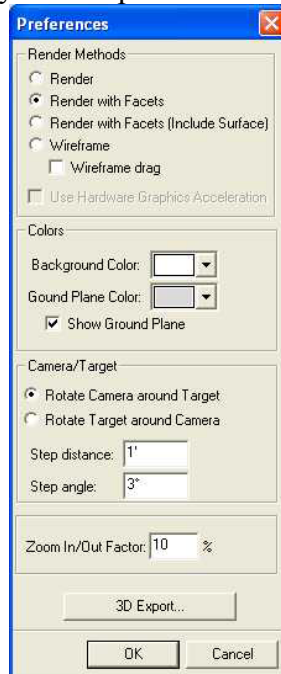

Lesson 24: Slide Show Animations

The Animate Button located in the Snapshot Manager dialog offers a slide show preview of snapshots. To get to the Snapshot manager click the camera icon found in the 3D Tools. This is meant as a preview only allowing sequential viewing of your snapshots taken while in the 3D rendering mode. It does not allow you to change timing.

Easy Crime Scene Walk Through:

EXERCISE:

Take snapshots while “walking” through the 3D rendered diagram in 3D viewer. For example at a crime scene you can go to the Options and set the Step Distance to about 2 ½ feet, then position camera and target height then click the forward arrow on you keyboard to move the camera exactly 2 1/’ each frame. This can show a perspective view of

someone walking through a building. Click the Camera button to save each movement to build a slide show animation.

For Collision Scenes:

In cases with more than one moving vehicle, it will be necessary to move each vehicle per frame. This can be a bit time consuming but the reward is knowing that our animations have been successfully used in court cases and is easy to defend. This is because you are using simple Time-Distance calculations you are familiar with and you have complete control over positioning so you can explain each frame if necessary.

- A.) Calculate vehicle positions manually frame by frame.
- B.) Import Win SMAC coordinates points if you have that program
- C.) To show vehicles in a straight line motion, you can use the “Linear Array” copy command found in the EDIT Tools to make a series of points designating center of mass for each vehicle at a specified distance.
- D.) Use the Edit or Properties button to put each time position on a separate layer and label the layer name to correspond. Then you can turn the layer you want on/off and have a saved record of your slides at each time increment.

Once the desired snapshots are taken in the 3D Viewer, return to the 2D Diagram Program and Snapshot Manager will be displayed. All of the snapshots you took are saved as a JPG and saved in the default path:

C:\Documents and Settings\My Documents\My Cad Zone\SnapShots

***FOR BETTER QUALITY 3D SCREEN SHOTS – SET YOUR SCREEN RESOLUTION AS HIGH AS POSSIBLE BEFORE TAKING SNAPSHOTS**

EASY ANIMATIONS

Many users are using PowerPoint, Windows Movie Maker and other software to build slide show animations with the 3D snapshots. We also provide a 3D Export function to allow users with more sophisticated animation and simulation programs to use 3D data.

By sticking with simple time-distance relationship illustration you can show your slide show in court and be able to easily explain and defend how you derived your presentation materials. (Conversion: MPH x 1.466 = feet/second)

TIPS:

Use the top view button in 3D viewer to show a colored version of your “Plan View,” looking straight down.

Place your camera into a vehicle and set height to witness perspective.

SIMULATIONS USING CRASHZONE-CRIMEZONE USING POWERPOINT AND OTHER PROGRAMS

Create better visual representations for reports and courtroom presentations.

PowerPoint or Movie Maker?

PowerPoint is best for overall ease of use and presentations since you can stop an any frame and restart the slide animation part way through. The resolution for display is also better. Movie maker is a bit faster with the drag and drop interface of inserting slides but does not give you as much control and viewing resolution is not as sharp.

PROGRAM USER RESOURCES:

Training Movies CD & Getting Started hand booklet

BUILT IN ROBO HELP – PRESS “F1” button or go to Help pull down when you are in the program. You will find EXCELLENT documentation and examples!

WEBSITE RESOURCES at: www.cadzone.com

- Visit our TRAINING section for lots of good materials.
- Visit our online Discussion Group for tips and topics from other end users and staff.

Free Technical Support: 503-641-1342

Or info@cadzone.com

CHECK THE “UPDATES” SECTION www.cadzone.com

UPDATES BUTTON FOUND AT THE TOP OF OUR HOME PAGE FOR FREE
DOWNLOADABLE UPDATES FOR THOSE WHO CURRENTLY HAVE A
LICENSED VERSION 7

Please let us know how we can improve our software to better serve you !